

our service alone could make you our customer

# 3 AND 4-YARD COMPACTORS

“equipping the world for a better environment”

# CRAM-A-LOT®

SOLID WASTE AND RECYCLING EQUIPMENT



Photo shows  
3 Yd. compactor  
and 40 Yd. receiver  
container with  
thru-the-wall installation.

Machines are completely  
UL listed to U.S. and  
Canadian safety standards



## MODELS

CO-03 CH-03  
CX-03 CO-04  
and CH-04

The above models are  
completely UL listed.

**Model CX-04**  
is not UL Listed

Designed for heavy commercial, industrial and mini-transfer stations.  
Engineered to handle above average quantities of refuse when transfer  
station is not applicable.

*Rental and Leasing Program Available*

*Parts and Labor are Warranted for One Year  
against materials and workmanship under normal usage.*

## J.V. MANUFACTURING, INC.

BALERS • COMPACTORS • CONTAINERS • TRANSFER STATIONS

701 Highway 265-S P.O. Box 229 (501) 751-7320

Phone 1-800-678-7320 FAX (501) 751-7774

SPRINGDALE, ARKANSAS 72765-0229

[www.cram-a-lot.com](http://www.cram-a-lot.com)

DISTRIBUTED BY:





**CRAM-A-LOT® Compactors can be custom designed and factory installed to suit your special applications.**

**COMPACTOR SPECIFICATIONS**

MODEL	CO - 03	CH - 03	CX - 03	CO - 04	CH - 04	CX - 04
Charge Box Capacity	3 cu. yd.	3 cu. yd.	3 cu. yd.	4 cu. yd.	4 cu. yd.	4 cu. yd.
WASTEK Rating	2.40	2.40	2.40	2.80	2.80	2.80
Clear Top Opening	62"x58.5"	62"x58.5"	62"x58.5"	62"x58.5"	62"x58.5"	62"x58.5"
Cycle Time	54 sec.	47 sec.	64 sec.	54 sec.	64 sec.	52 sec.
Total Force, Normal Maximum	56,500 lbs. 67,900 lbs	56,500 lbs. 67,900 lbs	76,900 lbs. 92,300 lbs.	56,500 lbs. 67,900 lbs.	76,900 lbs. 92,300 lbs.	104,600 lbs. 127,200 lbs.
Ram Face Pressure, Normal Maximum	31.9 psi 38.4 psi	31.9 psi 38.4 psi	43.4 psi 52.1 psi	27.3 psi 32.8 psi	37.1 psi 44.6 psi	50.5 psi 61.4 psi
Ram Penetration	13"	13"	13"	13"	13"	13"
Electric Motor, 3 Phase 230/460 VAC	10 hp	15 hp	15 hp	10 hp	15 hp	20 hp
Pump Size	10.5 gpm	12 gpm	12 gpm	10.5 gpm	12 gpm	36 gpm
Hydraulic Reservoir Capacity	33 gal.	33 gal.	33 gal.	33 gal.	33 gal.	105 gal.*
Hydraulic Cylinder, Bore Stroke Rod	6" 76" 3.5"	6" 76" 3.5"	7" 76" 4"	6" 76" 3.5"	7" 76" 4"	(two) 6" 76" 3.5"
Operating Pressure, Normal Maximum	2000 psi 2400 psi	2000 psi 2400 psi	2000 psi 2400 psi	2000 psi 2400 psi	2000 psi 2400 psi	1850 psi 2250 psi
Unit Weight	5620 lbs.	5700 lbs.	6100 lbs.	7240 lbs.	7420 lbs.	7800 lbs.
Construction, Floor Sides Breaker Bar Ram Face Ram Top Ram Sides Ram Bottom	.5" plate .1875" plate 6"x6"x1" angle .5" plate .25" plate 25" plate .5" AR plate	.5" plate .1875" plate 6"x6"x1" angle .5" plate .25" plate 25" plate .5" AR plate	.5" plate .1875" plate 6"x6"x1" angle .5" plate .25" plate 25" plate .5" AR plate	.5" plate .3750" plate 8"x6"x1" angle .75" plate .25" plate 25" plate .5" AR plate	.5" plate .3750" plate 8"x6"x1" angle .75" plate .25" plate 25" plate 5" AR plate	.75" plate .3750" plate 8"x6"x1" angle .75" plate .375" plate .375" plate .5" AR plate

\* Internal power unit not available

**STANDARD FEATURES**

- > UL/UL Canada listed Control Panel
- > Integral Power Unit
- > Replaceable UHMW Presshead Guides
- > Control Panel built into side of Compactor for easy access
- > Oil Sight Gauge
- > Replaceable Spin-on Cartridge Oil Filter
- > Heavy Duty Oil-tight Pushbutton Controls
- > Key-lockable Start Pushbutton
- > Automatic Single-cycle Operation



This equipment conforms to all current ANSI Z245.2 safety standards.

In order to provide the most currently engineered and designed equipment, we reserve the right to change specifications without prior notice. This brochure is intended to provide information only and should not be used in an arbitrary manner to judge equipment for any particular purpose. Performance may vary with application. Products must be installed and operated according to required standards, codes, regulations and safety procedures. Only the standard written warranty issued by J.V. Manufacturing, Inc. applies.

**OPTIONAL EQUIPMENT**

- > Full-container Light
- > Advance-warning Light
- > Fluid-filled Pressure Gauge
- > Remote Controls
- > Remote Power Unit
- > Multi-cycle Controls
- > Programmable Controlled Systems
- > Oil Heater
- > Spray Deodorizer Unit
- > Open Hopper-(for ground or dock loading)
- > Fully Enclosed Hopper with door
- > Through-the-wall Installation Kits
- > Walk-on or Drive-on Dock Mounts
- > Safety Interlock for a door or gate
- > Hydraulic Cart-dump Systems
- > Pre-crusher

	Dimensions	ALL-03	ALL-04
A -	Loading Sill Height	49 1/2"	55"
B -	Overall Height	62"	64"
C -	Overall Width	74"	79"

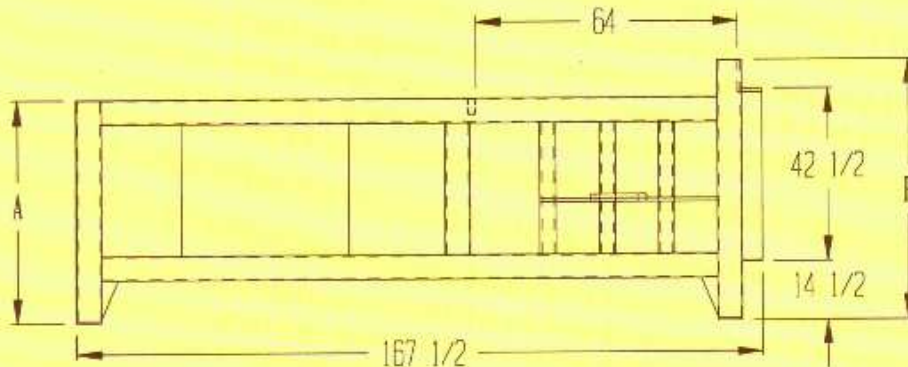

SIDE VIEW

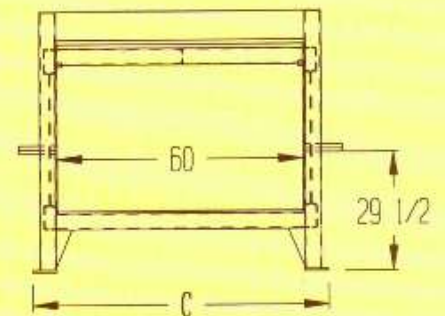

FRONT VIEW

**Manufacturing a full line of CRAM-A-LOT® Solid Waste Equipment**