

Side hinged hand operated intake door

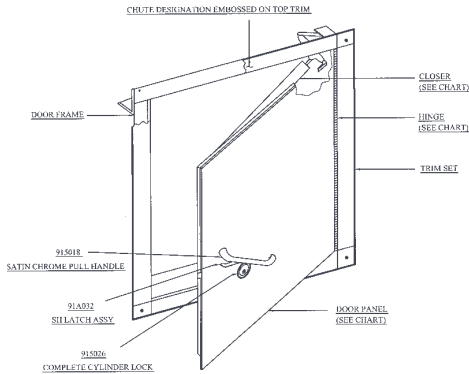

SIZE	DOOR PANEL	HINGE	HYD. CLOSURE
15" x 15"	2554NP	917302	2554NP
18" x 18"	2884NP	917301	2884NP
21" x 21"	2114NP	917300	2114NP
24" x 24"	2444NP	917313	2444NP

Bottom hinged hand operated intake door

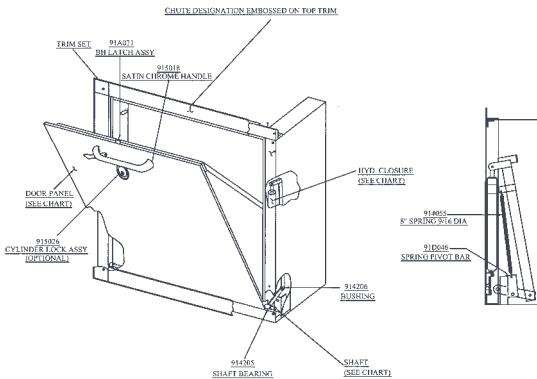

SIZE	DOOR PANEL	CONN. BAR	SHAFT	HYD. CLOSURE
12" x 15"	2554NP	91D033	91A141	91H001
15" x 18"	2584NP	91D105	91A089	91H002
18" x 18"	2884NP	91D105	91A091	91H002
21" x 18"	2184NP	91D105	91A096	91H002
24" X 24"	2444NP	91D086	91D087	91H002

**American
Trash
Management**
 1388 Sutter Street, Suite 920
 San Francisco, CA 94109



American Trash Management

Reducing the costs
and problems of trash
for high-rise and mid-rise
buildings

1388 Sutter Street, Suite 920
 San Francisco, CA 94109
 (800)488-7274
www.trashmanage.com

Who is American Trash Management?

Since 1990, American Trash Management (ATM) has provided sophisticated, cost-saving trash management products and services to private and public sector customers throughout the United States. ATM's mission is simple: *reduce the costs and problems of trash.*

Reducing the cost and problems of trash for high-rise and mid-rise buildings

The trash issues associated with high-rise and mid-rise buildings are unique. Limited space, complex equipment, difficult installs and intensive maintenance requirements create especially challenging trash problems for developers, architects, contractors and property managers.

ATM specializes in solving these trash problems. ATM offers a wide range of integrated products and services for high- and mid-rise buildings, at very competitive prices. From system design and integrated waste and recycling plans, to chute and compactor procurement and installation, to cleaning and repair services to a full line of spare parts, ATM is the leader in reducing the costs and problems of trash for high-rise and mid-rise buildings.

The Benefits of ATM's Products and Services

- System design—to ensure your trash system works for both tenants and staff
- Integrated trash & recycling plans—to satisfy municipal and planning requirements
- Wilkinson chutes—the market leader in high quality trash and linen chutes
- Chute-fed compactors—the perfect way to reduce waste disposal costs
- Chute installation—to make sure your project gets done right, on budget and on time
- Piiian Odor Control Systems—a safe, effective, all natural solution to odor problems
- Chute cleaning—to minimize tenant and employee complaints and problems
- Chute repairs—to keep your trash and linen chutes in good working order
- Chute parts—ATM carries a full line of replacement parts

To learn how American Trash Management can reduce the costs and problems of trash for you, please contact us:

Toll-free at (800) 488-7274

On the web at www.trashmanage.com

Type "A" discharge door

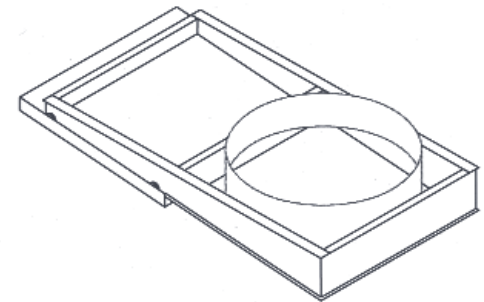

Type "H" discharge door

